

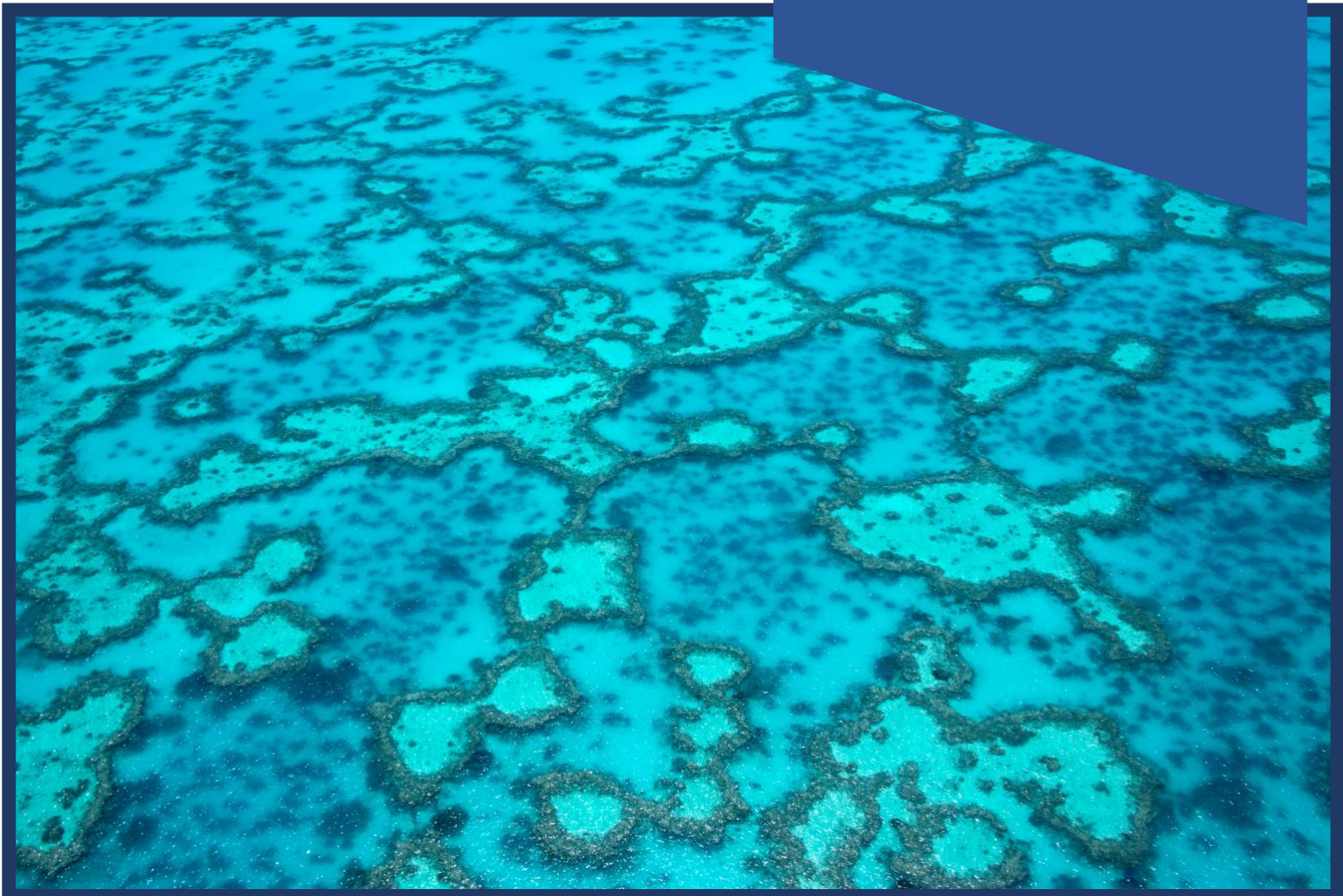

GLOBAL CORAL REEF
MONITORING NETWORK

GCRMN Implementation and Governance Plan

JANUARY 2019



GCRMN Implementation and Governance Plan

January 2019

*Adopted by ICRI members at the
33rd General Meeting, 5-7 December 2018, Monaco*

Citation: GCRMN 2019. GCRMN Implementation and Governance Plan. International Coral Reef Initiative (ICRI). Available: <https://www.gcrmn.net/about-gcrmn/igp/>

Cover photo: The Ocean Agency, <https://www.coralreefimagebank.org/coral-reefs-indonesia>



The Global Coral Reef Monitoring Network (GCRMN) Implementation and Governance Plan was prepared through a working group convened by the Secretariat of the International Coral Reef Initiative (ICRI) and the United Nations Environment Programme (UN Environment), pursuant to the resolution on GCRMN adopted at ICRI General Meeting 31 and UN Environment Assembly Resolution 2/12 on Sustainable Coral Reef Management.

Working Group: Francis Staub, ICRI and Jerker Tamelander, UN Environment (working group convenors); Dr. David Obura, CORDIO East Africa (lead author), Amanda Brigdale (Great Barrier Reef Marine Park Authority (GBRMPA, Australia)), Chuck Cooper (Vulcan Inc. USA), Wilfrid Deri (Ministry of State, Monaco), Hadi Yoga Dewanto (Ministry of Marine Affairs and Fisheries, Republic of Indonesia), Helen Fox (Vulcan Inc. USA), Akiko Hamada-Ano (South Pacific Regional Environment Programme (SPREP)), Jane Hawkrige (Joint Nature Conservation Commission (JNCC, UK)), Kirsten Isensee (Intergovernmental Oceanographic Commission of UNESCO - Ocean Science Section), Margaret Johnson (Great Barrier Reef Marine Park Authority (GBRMPA, Australia)), Justine Kimball (NOAA Coral Reef Conservation Program, USA), Tadashi Kimura (Japan Wildlife Research Center (JWRC)), Lucie Labbouz (Regional Activity Centre for Specially Protected Areas and Wildlife (SPAW-RAC)), Ben Palmer (Great Barrier Reef Marine Park Authority (GBRMPA, Australia)), Jason Philibotte (NOAA Coral Reef Conservation Program, USA), Serge Planes (Centre de Recherche Insulaire et Observatoire de l'Environnement (CRIOBE, France), Heidi Prislán (Department of Foreign Affairs and Trade, Australia), Manuel Gonzales Rivero (Australian Institute of Marine Science (AIMS)), Franz Paul Smith (Charles Darwin Foundation, Ecuador), David Souter (Australian Institute of Marine Science (AIMS)), Aurélie Thomassin (Ministry for Ecological and Solidary Transition, France), Karenne Tun (National Parks Board, Singapore).

Suggested citation: ICRI and UN Environment 2019. Global Coral Reef Monitoring Network (*GCRMN Implementation and Governance Plan*. 17p

Acknowledgements The input and advice of the following individuals is gratefully acknowledged: Lucy Bastin (EU Joint Research Center, JRC), Roger Beeden (Great Barrier Reef Marine Park Authority (GBRMPA), Australia), Claire Bissery (IFREMER, France), Pascale Chabanet (Institute for Research and Development (IRD), France), Andrew Chin (James Cook University, Australia), Guillermo Diaz-Pullido (Griffith University, Australia), Pete Edwards (NOAA, USA), Andrew Hoey (Australian Coral Reef Society Senior Research Fellow, ARC Centre of Excellence), Eduardo Klein (Ocean Biogeographic Information System, OBIS), Petra Lundgren (Great Barrier Reef Foundation, GBRF), Cate McElroy (Department of the Environment and Energy, Australia), Fiona Merida (Great Barrier Reef Marine Park Authority (GBRMPA), Australia), Patricio Miloslavich (UNESCO-IOC, GOOS Biology and Ecosystems Panel), Erin Peterson (Queensland University of Technology, Australia), Melita Samoilys (CORDIO East Africa), Jennifer Smith (UC San Diego, USA), Mahani Taylor (Department of the Environment and Energy, Australia), Hazel Thornton (UNEP-World Conservation Monitoring Center), Lauren Weatherdon (UNEP-World Conservation Monitoring Center), Liz Wren (Great Barrier Reef Marine Park Authority (GBRMPA), Australia).

Financial support towards development of the GCRMN Implementation and Governance Plan was provided by the governments of France, Sweden and United States of America.

International Coral Reef Initiative: The International Coral Reef Initiative (ICRI) is an informal partnership between nations and organizations which strives to preserve coral reefs and related ecosystems around the world.

www.icriforum.org

Global Coral Reef Monitoring Network: The Global Coral Reef Monitoring Network (GCRMN) supports ICRI by working through a global network to strengthen the provision of best available scientific information on, and communication of, the status and trends of coral reef ecosystems, for their conservation and management.
www.gcrmn.org

United Nations Environment Programme: The United Nations Environment Programme (UN Environment) is the leading global environmental authority that sets the global environmental agenda, promotes the coherent implementation of the environmental dimension of sustainable development within the United Nations system, and serves as an authoritative advocate for the global environment.
www.unenvironment.org

Executive summary

The Global Coral Reef Monitoring Network (GCRMN) has operated as the de facto global coral reef observing system since 1999, aggregating data from local levels to national, regional and global, and generating influential global and regional reports. It has played a strong role in building local and national capacity in coral reef reporting, to improve actions to sustain coral reefs in response to priorities set across all these levels. The development of this Implementation and Governance Plan (IGP) was mandated by a decision adopted at the 31st International Coral Reef Initiative (ICRI) General Meeting, in December 2016, and the IGP was adopted at the 33rd ICRI General Meeting in December 2018. The IGP strengthens GCRMN in tracking and reporting on coral reef status and trends, in keeping with current efforts to improve global observing networks of biodiversity and ocean systems. It enhances GCRMN's relevance in addressing key societal priorities to sustain reefs and the benefits they provide to people adopted at the global level, including the 2030 Agenda for Sustainable Development and the emerging post-2020 biodiversity framework, and tracking of progress in relation to these.

GCRMN has four goals, to: 1) improve understanding of coral reef status and trends, globally and regionally; 2) analyse and communicate coral reef biophysical, social and economic trends, providing science-based recommendations in support of raising awareness, management and policy development; 3) enable and facilitate greater utilization of coral reef data, including in research; and 4) build human and technical capacity to collect, analyse and report biophysical and socio-economic data on coral reefs.

GCRMN aggregates coral reef data provided by contributors and generates higher level reporting on reef status and trends. Decades of experience have identified hard coral cover and composition, fleshy algae and fish community structure as essential variables for describing reef health and future prospects, along with varied contextual information that includes socio-economic benefit and pressure interactions, environmental variables, and other ecological and functional variables (such as coral recruitment, coral bleaching, etc.). This IGP defines these key variables and identifies three quality levels at which data for these variables can be submitted. This data quality approach enables and facilitates aggregation of data from different sources, and also provides clear steps for capacity building to improve the data quality provided by contributors of all levels, and for use in decision-making at multiple levels.

The primary outputs of GCRMN are regional, global and thematic reports on coral reef status and trends, supported by online databases allowing for data curation and enhanced data access for a wide range of stakeholders. To the extent possible, GCRMN works towards open access to data in order to amplify its use in coral reef research, conservation, and relevant planning processes.

GCRMN is governed by a Steering Committee that derives its mandate from the ICRI General Meeting. The Steering Committee provides high level oversight, guidance, advocates for the GCRMN and helps secure support and resources. Implementation of the GCRMN is led by a Global Coordinator supported by a host institution, in close partnership with Regional Coordinators, time-bound Task Forces mandated by the Steering Committee, and relevant technical experts. The GCRMN Regional Networks, each with a Regional Coordinator, are the primary structures within the GCRMN, and bring together national networks, relevant institutions and *ad hoc* contributors of data. Key partners and supporters to the GCRMN include other international and inter-governmental bodies and entities with relevant mandates and expertise that support coral reef monitoring. Participation in the GCRMN is voluntary, based on shared goals contained in this IGP.

This Implementation and Governance Plan became operational in January 2019. To ensure the IGP remains fit for purpose it will be reviewed and revised periodically, including at least in 2025 and 2030, corresponding to milestones of the Sustainable Development Goals and the post-2020 biodiversity framework.

Contents

Executive summary	iv
1. Introduction	1
1.1. <i>Background</i>	1
2. Why is GCRMN needed?	1
2.1. <i>Importance of coral reefs</i>	1
2.2. <i>Societal justification for monitoring coral reefs</i>	2
Local and national importance.....	2
Global and regional importance.....	2
3. System design of GCRMN	3
3.1. <i>Goals of GCRMN</i>	4
Goal 1. Improve understanding of coral reef status and trends, globally and regionally.....	4
Goal 2. Analyse and communicate coral reef biophysical, social and economic trends, providing science-based recommendations in support of raising awareness, management and policy development.....	4
Goal 3. Enable and facilitate greater utilization of coral reef data, including in research.....	4
Goal 4. Build human and technical capacity to collect, analyse and report biophysical and socio-economic data on coral reefs.....	5
3.2. <i>Outputs - what the GCRMN produces</i>	5
Regional, global and thematic reports.....	5
Management/decision support reports.....	5
Data management and accessibility.....	6
4. Governance	6
4.1. <i>Who makes up the GCRMN</i>	6
4.2. <i>GCRMN as an ICRI Network</i>	6
4.3. <i>Steering Committee</i>	6
Task forces.....	7
4.4. <i>Global Coordination and Institutional hosting</i>	7
4.5. <i>Regional coordination</i>	8
National networks.....	9
4.6. <i>Related networks</i>	9
5. Implementing the GCRMN	9
5.1. <i>Ecological variables</i>	9
5.2. <i>Socio-economic variables and integrated monitoring</i>	10
5.3. <i>Data quality</i>	11
5.4. <i>Sharing and aggregating data</i>	11
5.5. <i>Capacity building</i>	12
6. The future of the GCRMN – a vision for 2030	12
7. Appendices	13
7.1. <i>Annex I. Acronyms</i>	13
7.2. <i>Annex II. GCRMN publications</i>	13
7.3. <i>Annex III - References cited</i>	14

1. Introduction

1.1. Background

The International Coral Reef Initiative (ICRI) is an informal partnership among countries, organizations and intergovernmental bodies, founded in 1994. ICRI's members came together to address the challenges faced by tropical coral reefs, because of their biodiversity and the benefits derived from them to adjacent and dependent communities and countries. Cold water coral ecosystems and ecosystems associated with coral reefs (i.e. mangroves and seagrasses) also fall within ICRI's mandate (www.icriforum.org), but this document focuses on monitoring of tropical coral reefs.

The Global Coral Reef Monitoring Network (GCRMN) was established by ICRI in 1995, initially with the primary task of reporting on the condition of the world's coral reefs in the context of development of the ICRI Call to Action. GCRMN produced global reports using a consistent approach between 1999 and 2008, and also published a number of thematic reports (Annex II). Now, multiple assessment and reporting processes from national to global levels (see section 2) require robust data and providing a common and consistent source for them is necessary.

The ICRI General Meeting in 2014 defined GCRMN's main purpose as follows: "*GCRMN supports ICRI by working through a global network to strengthen the provision of best available scientific information on, and communication of, the status and trends of coral reef ecosystems, for their conservation and management*". The ultimate aim of GCRMN is to support delivery of positive outcomes for coral reefs and dependent people and sectors by informing policy and management processes at global, regional and local levels. The development of this Implementation and Governance Plan was mandated by a decision at the 31st ICRI General Meeting, and the plan was adopted at the 33rd ICRI General Meeting in December 2018.

The GCRMN has operated as the de facto global coral reef observing system since 1999, generating influential global and regional reports. Since monitoring programs are generally developed to address local needs, a key role for the GCRMN is to provide guidance on data standards and approaches that maximize data quality at this level and facilitate aggregating data to larger scales. Through this, the value of the data is increased through sharing, contextualization with other data and contributing to multiple policy processes. The global scope of coral reefs means a common global framework for monitoring is needed to provide the necessary understanding of the state of coral reefs at a global scale.

The increasing need for data on earth systems, combined with increasing capability for generating, managing and using global datasets, has promoted growth of global monitoring of terrestrial, atmospheric and ocean systems. Working groups under the Global Ocean Observing System (GOOS) (Miloslavich et al. 2017) and the Group on Earth Observations Biodiversity Observation Network (GEOBON) (Muller-Karger et al 2018) are charged with bringing this experience to support the growth of global observing systems for ocean and marine biodiversity, including coral reefs.

2. Why is GCRMN needed?

2.1. Importance of coral reefs

Coral reefs are exceptionally biodiverse and productive. Ringing tropical coastlines, they play a unique role in the lives of coastal people and countries and are an immensely valuable asset from local to national levels (Wilkinson 2004, Burke et al. 2011, Beck et al. 2018). Coral reefs are the most species-rich marine ecosystem and play a role in the life cycle of one quarter of all marine fish species (Burke et al. 2008). Their productivity supports the livelihoods and food security of more than half a billion people in more than 100 countries, particularly Small Island Developing States (SIDS), and they are a trillion-dollar economic asset (Hoegh-Guldberg et al. 2015).

Coral reefs are also under significant direct pressure from human activities including fishing, pollution, recreation, transport and coastal development, and are uniquely vulnerable to ocean warming and acidification. This puts the ecological, social, and economic benefits they provide in danger, especially

as countries are intensifying their demands on ocean resources to deliver 'blue growth' and economic development.

Because of this, coral reefs are sensitive indicators of coastal ocean health, and particularly so for climate change and ocean acidification impacts, with implications for society and sustainable development (IPCC 2018). They have a prominent role from local to global levels as a flagship socio-ecological system, showing the state of nature, of peoples' dependency on ecosystem services, and of the ability of governance systems to both optimize and safeguard nature's benefits for current and future generations. The need for accurate data and information to inform decisions that promote sustainable development is increasing, and only increases the need for GCRMN and its outputs.

2.2. Societal justification for monitoring coral reefs

Local and national importance

At local levels, coral reefs are the foundation for integrated ecological, social and economic systems. Where people have lived and depended on reefs for generations, many have developed cultural and social practices and norms reflecting this dependence, and the vulnerability of reef and coastal systems. Modern coastal economies are equally dependent on reef ecosystem services, though this dependence is only recently being acknowledged and is often not built into sustainability practices. Monitoring of coral reefs can provide critical data, including of indigenous and local knowledge, that helps coastal residents and authorities understand the health of the reef, their dependence on its health, and the economic and financial consequences of reef decline. Thus, the societal need and justification for coral reef monitoring at local levels is high and requires design of monitoring systems to address local dynamics, key threats and socio-economic dimensions.

Design of local monitoring programmes should respond to local needs. GCRMN does not directly address design of local monitoring, but a key goal of GCRMN is to ensure that monitoring is globally consistent while being responsive to the local context. GCRMN will also promote an Integrated Monitoring approach at local levels (combining biophysical and socio-economic components) that is tied into local governance and adaptive management mechanisms (building on efforts underway e.g. in the Caribbean (UNEP/SPAW 2017)).

Global and regional importance

Maintaining the status and health of nature is written into the goals and targets of multiple global and regional agreements. Reporting on the health of coral reefs is specifically called for in or particularly relevant to many of them:

Agenda 2030 of the United Nations General Assembly identified 17 Sustainable Development Goals, of which SDG14, to "*Conserve and sustainably use oceans, seas and marine resources*" focuses on the ocean. For three of the ten targets within SDG14, coral reefs are particularly relevant and can be a flagship system:

- 14.2 - *By 2020, sustainably manage and protect marine and coastal ecosystems to avoid significant adverse impacts, including by strengthening their resilience, and take action for their restoration in order to achieve healthy and productive oceans;*
- 14.5 - *By 2020, conserve at least 10 per cent of coastal and marine areas, consistent with national and international law and based on the best available scientific information; and*
- 14.7 - *By 2030, increase the economic benefits to small island developing States and least developed countries from the sustainable use of marine resources, including through sustainable management of fisheries, aquaculture and tourism.*

Similarly, the benefits provided by coral reefs to people are embedded in other SDG targets (e.g. economic and social benefits, governance, planning, knowledge transfer and research) so socio-economic and integrated monitoring of coral reefs can help assess achievement of the SDGs for coral reef countries.

Convention on Biological Diversity (CBD) - coral reefs are a flagship ecosystem for Aichi Target 10, and the focus of Decision XII/23.¹ GCRMN will provide the core indicators to be used by countries to

¹ Priority Actions to Achieve Aichi Biodiversity Target 10 for Coral Reefs and Closely Associated Ecosystems) was adopted in Pyeongchang, Democratic Republic of Korea, in October 2014

attribute and reduce multiple stressors causing reef decline and to inform and monitor the post-2020 targets.

UN Framework Convention on Climate Change (UNFCCC) - coral reefs, with polar systems, are a flagship ecosystem for achieving the Paris Agreement and can provide a sensitive indicator of the consequences of warming above 1.5°C. Coral reefs are also included in Nationally Determined Contributions (NDCs) and National Adaptation Plans of Action of some State Parties, so credible data for monitoring progress is needed.

United Nations Environment Assembly (UNEA) - in Resolution 2/12 on coral reefs², UN member states called on UN Environment to “support further development of coral reef indicators, regional coral reef assessments, and preparation of a global report through GCRMN”.

Regional agreements - the importance of coral reefs is highlighted in tropical Regional Seas Conventions and Action Plans (e.g. Cartagena Convention in the Caribbean), relevant Large Marine Ecosystems (e.g. the Agulhas-Somali Current LME), and in regional economic blocs (e.g. the Asia-Pacific Economic Community (APEC)) and others. Providing core indicators on coral reef health and socio-economic benefits for these regional instruments will help countries report on their obligations and develop regional strategies for coral reef protection.

Assessment processes – that require coral reef data include the UN Regular Process for the World Ocean Assessment, the Intergovernmental Panel on Climate Change (IPCC) and the Intergovernmental Science-Policy Platform on Biodiversity and Ecosystem Services (IPBES) assessments. There are also regional assessment processes such as the State of Marine Ecosystems and shared Living Marine Resource in the Wider Caribbean (Gulf of Mexico and CLME+ Region) under the UN Environment Programme/Caribbean Environment Programme (UNEP/CEP) that are focused on coral reefs and associated ecosystems.

3. System design of GCRMN

Three key design elements for an ocean observing network responding to societal priorities have been defined (UNESCO 2012):

- **justification or goals** for the observing system in relation to societal priorities;
- **processes** defining what data is collected, how and by whom;
- **outputs**, being syntheses of the observations to inform decisions based on the societal priorities.

² [UN Environment Assembly resolution 2/12 on Sustainable Coral Reefs Management](#)

The Drivers Pressures Status Impact Responses (DPSIR) model is often used to evaluate human impacts and mitigation of these impacts (Patricio et al. 2016, Miloslavich et al. 2018). More holistic interpretations of the model have been developed, incorporating aspects of ecosystem-based management and socio-ecological systems (Kittinger et al. 2012, Kelble et al. 2013, Wongbusarakum et al. 2014), and to facilitate adaptive management responses to pressures, trends and capabilities (fig. 1). This is useful for the GCRMN to ensure that:

- a) the goals for monitoring relate to sustainability of the reef social-ecological system as a whole;
- b) monitoring variables are focused on key Pressures, Status and Trends, as well as Benefits; and
- c) outputs are targeted to support Responses, which may directly or indirectly address any parts of the model.

3.1. Goals of GCRMN

GCRMN has three primary goals, with capacity building as a fourth, overarching priority. Specific objectives are identified under each goal:

Goal 1. Improve understanding of coral reef status and trends, globally and regionally

Objectives

- 1.1 Quantify change in core components of the reef community
- 1.2 Attribute changes and impacts on coral reefs to key drivers
- 1.3 Identify and interpret reef recovery processes important for maintaining and restoring reefs
- 1.4 identify and interpret trends in key social and economic drivers and benefits in relation to coral reef status and trends.

Goal 1 sets the principal data requirements of the GCRMN. The objectives progress in complexity, whereby 1.1. defines the minimum measures necessary to quantify change reliably; 1.2 enables attribution of change to drivers; 1.3 enables interpretation of recovery processes and actions; and 1.4 assesses social, economic and natural changes in a more integrated whole.

Goal 2. Analyse and communicate coral reef biophysical, social and economic trends, providing science-based recommendations in support of raising awareness, management and policy development.

Objectives

- 2.1 Support evidence-based decisions on management and policy responses to coral reef biophysical, social and economic trends.
- 2.2 Support assessments and reporting that track progress towards internationally adopted goals and targets, in relation to environmental, social and economic targets.

Goal 2 addresses GCRMN products in support of (adaptive) management and policy action (2.1), and aggregated reporting in ways relevant for tracking delivery of internationally adopted goals and targets (2.2). Tools to deliver on these objectives include the regional and global reports, and other decision support tools targeting adaptive management, policy and varied stakeholder audiences.

Goal 3. Enable and facilitate greater utilization of coral reef data, including in research.

Objectives

- 3.1 Support and promote exchange of information and sharing of knowledge about reef status, trends and responses.

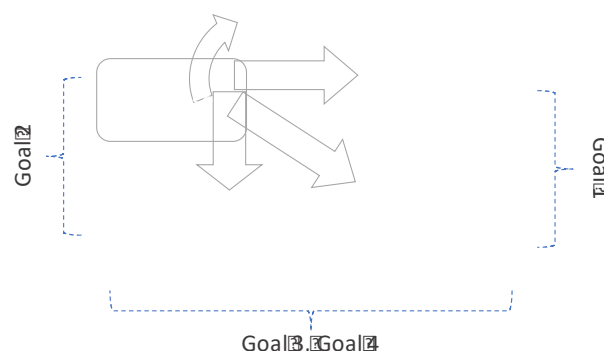

Fig. 1. A holistic interpretation of the Driver Pressure State Impact Response (DPSIR) model that incorporates ecosystem-based and adaptive management principles to identify priority questions, variables and responses for an observing system. Monitoring focuses on status and trends, plus key pressure and benefit variables, and is used to inform management and policy responses in relation to these, and overarching drivers.

3.2 Contribute to and operationalize innovations and their application in coral reef monitoring, research and modelling.

Goal 3 addresses managing, securing and making data accessible on open platforms (3.1) and adopting technical innovations that are changing by orders of magnitude the type and availability of data on coral reef systems (3.2).

Goal 4. Build human and technical capacity to collect, analyse and report biophysical and socio-economic data on coral reefs.

Objectives

- 4.1 Identify capacity building needs at local, national and regional levels, and support the network members in meeting these needs.
- 4.2 Generate and report on relevant metrics demonstrating delivery of GCRMN goals 1, 2 and 3.

Building human and technical capacity is an important function of GCRMN, both as a network of contributors/partners and as a technical body. The capacity building approach seeks to a) maximize data submission to the GCRMN, to cover as much reef area as possible regionally and globally, from as broad a range of stakeholders as possible; and b) provide an in-built evaluation process that incentivizes capacity building and delivery of Goals 1-3.

3.2. Outputs - what the GCRMN produces

The main GCRMN outputs address Goals 2 and 3 - reporting the data that aggregated in ways that contribute to conserving coral reefs and securing their benefit flows (Goal 2), and making the data available for reuse and general access to advance science and management that advance coral reef conservation and sustainability (Goal 3). These are:

1. regional, global and thematic reports, to improve understanding of reef health and future prospects;
2. decision-support outputs, to inform policy and management, and track progress towards internationally agreed upon targets, and
3. improved access to and integration of data on coral reef health and trends.

Improved data quality enables more robust interpretation of trends in coral reef state and socio-economic drivers and dependencies, and thus improved quality of all three sets of GCRMN outputs.

Regional, global and thematic reports

Regional reports are the primary mechanism and outputs for aggregating data and activating the networks of GCRMN contributors, with a global report being produced on the basis of these regional efforts. The regional reports will be produced by regional GCRMN networks, responding to regional priorities and governance structures. As of 2018, three regional reports following the new GCRMN model have been produced: the Wider Caribbean (Jackson et al. 2014), the Western Indian Ocean (Obura et al. 2017) and the Pacific (Moritz et al. 2018), and further regional reports are underway. A global report will be published in 2020, and subsequently to coincide with the review processes for SDG achievement in 2025 and 2030 as well as the post-2020 biodiversity framework.

Thematic reports may also be produced, such as has been done in the past on tsunami impacts (Wilkinson et al. 2005), to deliver results focused on particular topics of regional to global importance.

Management/decision support reports

Reports from individual monitoring programmes targeting local management is the mandate of individual programmes rather than the GCRMN as a network. However, improved capacity and data quality encouraged by the GCRMN also support improved reporting locally (fig. 1). Basic data may only allow addressing Objective 1.1 (quantifying change), but improved data quality allows addressing Objectives 1.2-1.4 (attributing change, understanding recovery options and addressing benefit flows), improving the ability of individual programmes to report information of increased value for management and policy locally. Further, access to shared data from a broader geographic scale (see section 4.4) enables local programmes to contextualize their data and improve reporting. Building the network

governance structures, capacity building processes, and data sharing tools to support GCRMN participants in achieving their local goals is a core design element of the GCRMN.

Data management and accessibility

Goal 3 is focused on enabling and facilitating greater utilization of coral reef data. GCRMN will seek to establish regional data repositories supporting each regional report, with links to other open and shared resources. The repositories may include online tools improving access to and exploration of the data. Mechanisms and access agreements to link, share and explore data will be developed. Key features for online tool development will be to meet the reporting goals of the GCRMN, including:

- to facilitate regional reporting processes such that subsequent reports update the existing repository and outputs are easy to produce;
- to facilitate GCRMN contributors and other users to prepare reports for local use in improving coral reef management and policy;
- to facilitate tracking and reporting achievement on the conventions and targets for which coral reef data is valuable.

4. Governance

The governance structure of GCRMN addresses participation, strategic and technical oversight as well as global and regional coordination of the network. GCRMN's governance framework draws on guidance for global observing networks including GOOS (UNESCO 2012) and GEOBON (GEOBON undated; Navarro et al. 2017).

4.1. Who makes up the GCRMN

GCRMN aggregates coral reef data from contributors. Contributors are organized through regional networks, semi-formalized on the basis of Regional Seas programmes or other relevant structures. The regional networks and their participants form the core of the GCRMN and provide the foundation for its activities and for achievement of its objectives. This is a primary strength of the GCRMN, bringing together a large number of collaborators from across the entire global distribution of coral reefs. *Ad hoc* contributors may include a range of public, private, academic or civil society entities, individuals, short-lived projects, or volunteer networks with independent requirements and data standards, such as Reef Check, which has collected globally distributed data and has contributed to the GCRMN since the 1990s. In all cases, contribution of data is on a voluntary basis.

Participation in GCRMN is determined by contribution of data, which may be characterized by:

- adhering to a data sharing agreement and/or principles established by the relevant Regional Network;
- submission of metadata and data quality specified in this Implementation and Governance Plan.

4.2. GCRMN as an ICRI Network

As an Operational Network of ICRI, GCRMN's structure and governance mechanisms, as well as amendments to these, are approved by the members of ICRI at its General Meetings. The ICRI General Meeting may also take appropriate actions related to GCRMN following the organization and management procedures of ICRI, including specific requests to the GCRMN Steering Committee or Global and Regional Coordinators (see below).

4.3. Steering Committee

The GCRMN Steering Committee provides global oversight of GCRMN. It guides and advises the Global and Regional Coordinators and advocates for GCRMN globally to support its further development and to ensure impact.

The specific functions of the Steering Committee are to:

- Provide high level oversight of the delivery and periodic review of the GCRMN implementation and governance plan and budget, including global and regional coordination, activities, outputs, capacity building and quality assurance;
- Provide advice, guidance and follow-up to the Global Coordinator on the implementation of decisions arising from ICRI General Meetings;
- Provide advice and guidance on bringing items to ICRI General Meetings for consideration by ICRI members;
- Provide support, links and advocate for the GCRMN in relevant national, regional and international fora and processes to maximize uptake and value generated from GCRMN activities and outputs, and to expand strategic partnerships of the network;
- Assist in securing financial and in-kind support and resources for GCRMN activities and outputs;
- Establish and provide oversight of permanent or temporary Task Forces (see below) to provide specific technical advice and solutions for the effective delivery of GCRMN activities;
- Promote, facilitate and guide capacity building in regional networks in accordance with the IGP.

Membership of the Steering Committee will comprise:

- ICRI Host Secretariat representatives (one per country) - Chair
- UN Environment
- 2 non-government/technical ICRI members
- 2-4 major supporters of the GCRMN (see below)
- Global Coordinator
- 2-4 Representatives of Regional Networks
- Invited members such as leads of current Task Forces
- Host institution

Major supporters of the GCRMN may be government or non-government ICRI Members that provide significant financial, in-kind or technical support to the network.

The Steering Committee may meet during or prior to ICRI General Meetings, or as needed between ICRI General Meetings. Meetings will be conducted in person, or by video or phone as appropriate.

Task forces

To address specific priority issues, Task Forces may be established by the Steering Committee. Task Forces are time-bound and output-oriented, operate in close consultation with the Global Coordinator and will report to the Steering Committee. Task force composition is approved by the Steering Committee on the basis of recommendation by the Global Coordinator. Each Task Force nominates a member to represent them on the Steering Committee when appropriate.

Topics that may be addressed through specific task forces include data quality, data sharing and access, socio-economic monitoring, policy and communication, as well supporting preparation of global, regional or thematic reports.

4.4. Global Coordination and Institutional hosting

The GCRMN Global Coordinator leads the network, day-to-day operations and liaison. Specifically, the Global Coordinator will:

- oversee network activities at global level, including data management, quality control, analysis, and reporting;
- maintain active liaison with the Steering Committee, and the Task Forces;
- maintain active liaison with regional coordinators, network contributors, and support and guide them in relation to monitoring and reporting;
- seek to expand participation in the network;

- lead the development of products, in particular the global, regional and thematic reports, as well as conceptualization of new products and development and resourcing of activities that contribute to achieving GCRMN's goals;
- represent the network internationally and liaise/partner with other relevant bodies and organizations;
- support regional efforts to enhance capacity and capability of network members;
- act as the secretariat for the Steering Committee, including setting of meeting schedules, development of agendas in consultation with the Steering Committee chair and the provision of papers and meeting reports.
- oversee and promote communication on GCRMN activities and outputs, including through the website, press interactions and social media.
- develop a fundraising strategy for the GCRMN (for global coordination, and in partnership with regional networks as relevant) and management of the global coordination budget.

Hosting of the Global Coordinator must be facilitated by an institution or organisation that can provide necessary administrative support, scientific leadership and facilitate constituency engagement. The host institution may change periodically, through a process initiated and approved by means of decisions of the ICRI General Meeting and led by the GCRMN Steering Committee.

4.5. Regional coordination

The basic operational level of the GCRMN is the Regional Network. The current set of GCRMN regions (Box 1) has evolved over the last two decades, reflecting working relationships among countries and institutions. The UN Environment Regional Seas programmes provide the primary institutional mechanism for coordination or facilitation of many GCRMN regions, but the operating procedures in each region vary according to the regional context. Each regional network should have a Regional Coordinator who is supported by a Regional Committee. Regional networks should, where possible, be linked to regional bodies such as the Regional Seas, which often provide the most appropriate home for a Regional Coordinator. The Regional Committees may be made up of national and/or institutional representatives, as well as technical members and contributors.

Box 1. Suggested GCRMN regions

Caribbean Brazil/SW Atlantic Western Indian Ocean Pacific Islands Eastern Tropical Pacific East Asian Seas Red Sea and Gulf of Aden ROPME Sea Area South Asia Australia
--

GCRMN Regional Committees, including the Regional Coordinator, operate under the guidance of the Global Coordinator, to:

- facilitate network activities at regional level, including data collection, analysis, management, quality control and reporting;
- lead regional efforts to enhance capacity and capability of network members;
- maintain active liaison with Regional Committee members, other relevant bodies and organizations and contributors, and support and guide them in relation to monitoring and reporting;
- facilitate regional reporting of coral reef health, including aspects of data storage and sharing, and establishing regional data repositories supporting each regional report;
- act as a go-between between regional efforts and global reporting;
- seek to expand the membership of the network;
- develop and implement activities and prepare products responding to needs of the region;
- actively participate in inter-regional network activities; and
- when required, represent the regions and contribute regional perspectives to the Steering Committee.

Given the specificity and differences among regions, a single 'one size fits all' framework cannot be proposed for all regions. Further, the boundaries and identities of the GCRMN regions may change over time. The Global Coordinator and Steering Committee can in this case provide guidance and support to ensure regional structures can provide the functions and outputs needed, through regionally relevant coordination mechanisms, and to ensure global coverage among regions.

National networks

Regional networks may where relevant be made up of national networks. This includes e.g. networks hosted by a key institution such as those responsible for Integrated Coastal Zone Management and bringing together individual coral reef monitoring programmes associated with MPA systems, other conservation or research programmes as well as non-specialist, volunteer and community monitoring programmes. This national-regional hierarchical system can facilitate networking and data submissions from contributors. Both national and regional networks have an important role in training and awareness-raising to sustain or support development of monitoring programmes and data collection and build support among stakeholders for monitoring and management actions.

4.6. Related networks

GCRMN will maintain close liaison with other relevant networks, entities and initiatives, including as identified below. Additional ones may be identified by the Steering Committee:

- UNESCO-IOC including the Global Ocean Observing System (GOOS) and its Biology and Ecosystems Panel; the Ocean Biogeographic Information System (OBIS), which may play a key role in data sharing and access; IODE Best Practices repository; the Global Ocean Acidification Observing Network (GOA-ON); the UNESCO Decade of Ocean Science and Sustainability (2021-2030); and the Ocean Teacher Global Academy (OTGA);
- The Marine Biodiversity Observation Network (MBON) of the Group on Earth Observation's Biodiversity Observation Network (GEO BON), including in relation to fostering integration with networks focused on associated ecosystems, in particular seagrass beds and mangroves.
- The International Coral Reef Society (ICRS), which provides a global network of scientific expertise;
- the GoFair Implementation Network to document processes and facilitate implementation of open access objectives;
- the Biodiversity Indicators Partnership (BIP), which manages the processing of variables for CBD Aichi Target reporting, of which coral cover is one;
- the Inter-Agency and Expert Group on Sustainable Development Goal Indicators (IAEG).

5. Implementing the GCRMN

This section provides an overview of the principles for implementing the GCRMN, focusing on the variables for monitoring, how to assure data quality, data sharing and aggregation, and capacity building.

Because of the complexity of monitoring coral reefs, there is high variability in the variables and methods used by monitoring programmes as well as approaches for bringing data together. Detailed guidance on these aspects is contained in a separate GCRMN Monitoring Guidance document. A first draft of this document accompanies this IGP, for use in implementation of this plan. It will be a living document, under the guidance of the Steering Committee, to keep up with emerging challenges and opportunities.

5.1. Ecological variables

Historically, the GCRMN has focused on coral reef ecological data collected using transects and quadrats, establishing community standards and a focus on hard coral cover as the primary variable for reporting reef health, supported by variables on algae and fish communities (see Jackson et al. 2014, Obura et al. 2017, Moritz et al. 2018). A proliferation of measurement methods over recent decades and the emergence of new technologies and autonomous instruments requires a renewed statement of data and methods standards for the GCRMN (see Obura et al. 2019).

In this regard, the Essential Variables concept emerging from the Global Climate Observing System and its Essential Climate Variables (<http://climatemonitoring.info/ecvinventory/>), the Essential Biodiversity Variables (EBVs, Pereira et al. 2013) and the Essential Ocean Variables (EOVs) is salient. Implementation mechanisms for the GCRMN are based on convergence between the needs of the GCRMN and work under GOOS and GEOBON to establish core variables for monitoring ocean biodiversity (Miloslavich et al. 2018, Bax et al. 2018, Muller-Karger et al. 2018).

Ten biology and ecosystem EOVs were initially identified, of which hard coral cover (and composition) and zooplankton abundance are the most advanced (Miloslavich et al. 2018). The maturity of hard coral cover as an EOv is a result of global reporting by the GCRMN and the scientific community. Two other variables are increasingly recognized to be important in understanding reef health - algae cover and fish abundance (Table 1).

Table 1. Key variables used in GCRMN reporting.

Variable	sub-variables	Justification
Hard coral cover (percent)	Composition (by morphology, genus)	Hard corals are the architects of coral reefs, and reporting percent hard coral cover as an aggregate indicator is the single most reported measure of coral reef health.
Fleshy algae cover	Sum and components of fleshy, macro and turf algae	Different algal groups serve unique functional roles in reef communities - fleshy, macro and turf algae are primary competitors to corals for occupying reef substrates.
Fish abundance and diversity	Abundance and biomass, by functional groups and/or key species	Fish are key consumers on coral reefs, some control coral-algal interactions, others are key indicators of pressures and/or ecosystem health.

Formal descriptions of all EOVs are maintained in periodically updated Specification Sheets developed by the GOOS Biology and Ecosystems Panel (www.goosocean.org/eov). This IGP and its supporting Technical Plan focus on the mechanisms for collecting and aggregating data to generate these variables, and should be read in conjunction with the EOv specification sheets. Method and protocol manuals describing relevant ways to measure the EOVs in the field are presented on a continuously updated website (see Box 2).

Box 2 - core documents required to undertake GCRMN monitoring

1. The **GCRMN Implementation and Governance Plan** (this document) - at <http://www.gcrmn.net/igp>
2. The **GCRMN Technical Note** - specifying the variables and data quality model - at <http://www.gcrmn.net/igp>
3. The **Essential Ocean Variable Specification Sheets** (for coral, algae and fish) - at www.goosocean.org/eov.
4. **Compilation of methods** supplying coral cover, algae cover and fish abundance data to recognized data quality levels - see <http://www.gcrmn.net/methods>

Additional variables are also desirable but may require greater resources and capacity for monitoring. These include coral recruitment, abundance of major mobile invertebrates, coral condition (e.g. bleaching and disease) and physical and other water properties such as temperature, nutrients, etc. (see GCRMN Monitoring Technical Note, 2018).

The data quality model adopted for the GCRMN identifies three 'levels' for each of these variables, starting with the most basic or minimum requirement for submitting data to the GCRMN - coral cover at level 1. Details are presented in the accompanying GCRMN Monitoring Technical Note.

5.2. Socio-economic variables and integrated monitoring

The GCRMN has laid out some principles to forge integrated monitoring of biophysical and socio-economic information to inform more effective adaptive management processes (UNEP/SPAW 2017). This is consistent with the emerging science of social-ecological systems, and recognition of the importance of a) recognizing the social and human dimensions of natural resource use and governance more holistically and consistently with many traditional and local community practices, and b) effectively measuring and managing the activities and people that are the prime beneficiaries and stakeholders in coral reef health, as well as being drivers of pressures.

Details for socio-economic monitoring are not as well developed as for ecological variables. This will be an area of further development for GCRMN.

5.3. Data quality

Capacity for monitoring differs from site to site and contributor to contributor, depending on the intended use of observations, and the capacity and resources available. To ensure contributed data is interoperable and to reduce uncertainty, data quality criteria have been developed. The approach (Table 2) facilitates the submission of data in a transparent and accountable way, and encourages strengthening of monitoring processes. It also enables sub-setting of data based on data quality, and facilitates reporting of uncertainty. Goal 4 uses the data quality model to organize and evaluate capacity building, providing practical steps that improve data quality over time.

Table 2. Uncertainty and interoperability for GCRMN data.

Uncertainty	Interoperability
Reporting the uncertainty related to a specific measurement enables users of the data to a) know what confidence can be placed in it, and b) assess the comparability of different measurements of the same parameter (Newton et al. 2015).	Interoperability refers to the range of data that can be combined and analysed with other data within the system. Interoperability requires that data quality is transparent and guidance on what can be done is explicit. i.e. that uncertainty is low.
Uncertainty for the GCRMN is documented through metadata. It is through reporting on the metadata that uncertainty is explicitly acknowledged.	Uncertainty reported from the metadata can be used to select how data sets can be combined, as well as for example to exclude data with levels of uncertainty past a certain threshold.

Assessing data quality in the GCRMN is focused on compiling comprehensive metadata on the methods, sampling, capacities and other aspects of monitoring and the teams involved. The approach is based on 'readiness levels' (UNESCO 2012), which establish small but concrete steps that help programmes improve data quality through three levels (Table 3). Because these steps are quantifiable and affect the 'rating' of a contributor, the approach also provides both motivation and tangible steps to improve through capacity building (section 4.5).

Table 3. Data quality levels.

	Essential Variable	Comments	Capacity required
Level 1	Minimum requirements for reporting.	Provides results with a minimum level of certainty to understand trends and support basic management decisions	Accessible to observers with minimal essential training and experience.
Level 2	Improved/intermediate standards for reporting.	Includes basic sub-variables for providing contextual information.	Requires greater experience and training, and investment in capacity.
Level 3	Highly recommended as the standard for reporting.	including prescribed sub-variables and contextual information to support attribution of changes and strong management decisions.	Requires continued/periodic investment in capacity.

These levels correspond to past practice in some GCRMN regions of e.g. basic, intermediate and advance, or required, recommended and highly recommended levels. However, this new approach is more general, putting the focus on the variables rather than the methods, allowing flexibility as methods change with technology (as under Goal 3.2).

5.4. Sharing and aggregating data

Data sharing in the GCRMN will be implemented through applying FAIR principles (Table 4). A core component of the FAIR principles is documentation of methods and data quality through metadata. This complements and strengthens the data quality and capacity building approach as the metadata both documents good practice and provides information used in assessing improvements over time.

Table 4. FAIR principles state that data should be:

Principle	Detail
Findable	F1. (Meta)data are assigned a globally unique and persistent identifier

	F2. Data are described with rich metadata F3. Metadata clearly and explicitly include the identifier of the data they describe F4. (Meta)data are registered or indexed in a searchable resource
Accessible	A1. (Meta)data are retrievable by their identifier using a standardized communications protocol A1.1 The protocol is open, free, and universally implementable A1.2 The protocol allows for an authentication and authorization procedure, where necessary A2. Metadata are accessible, even when the data are no longer available
Interoperable	I1. (Meta)data use a formal, accessible, shared, and broadly applicable language for knowledge representation. I2. (Meta)data use vocabularies that follow FAIR principles I3. (Meta)data include qualified references to other (meta)data
Reusable	R1. Meta(data) are richly described with a plurality of accurate and relevant attributes R1.1. (Meta)data are released with a clear and accessible data usage license R1.2. (Meta)data are associated with detailed provenance R1.3. (Meta)data meet domain-relevant community standards

Source: <https://www.go-fair.org/fair-principles/>

The long-term aim for the GCRMN is for all compiled data to be accessible in an open online platform. However, to accommodate constraints of data contributors (e.g. from the perspective of research and related to proprietary data), data access restrictions or moratoria may be established (e.g. based on time), for periodic revision.

5.5. Capacity building

Capacity building has been a core component of the GCRMN since inception, and targets delivery of goals 1-3. The small island and developing states that host most of the world's coral reefs face major resource and capacity constraints, and this remains a challenge even today. The focus of capacity building is the people that make up the monitoring and analysis teams in these countries and across GCRMN regions. The mechanism for assessing capacity development is provided by the data quality model - by tracking the metadata submitted by GCRMN contributors. Thus, objective 4.1 focuses on the monitoring teams and the support they need to improve skills and safety in the field, analysis and reporting. Objective 4.2 focuses on measuring capacity through the outputs of the GCRMN - reports in goal 2 and greater utilization and sharing of data in goal 3.

6. The future of the GCRMN – a vision for 2030

Pressures on coral reefs, coral reef status, and our capabilities for monitoring and reporting these constantly change. To account for such changes and adjust GCRMN's approach as may be required, this IGP will be reviewed at 5-year intervals, or as directed by the GCRMN Steering Committee.

A brief strategic plan with milestones and more specific targets for GCRMN over the coming decade will be prepared, aligned with key dates of the 2030 Agenda for Sustainable Development and the post-2020 biodiversity framework. A Monitoring and Evaluation (M&E) process will also be established. This will build on the data quality metadata submitted by contributors and aggregated to national and regional levels, in relation to understanding reef processes (Goal 1), providing recommendations for and tracking of management and policy targets (Goal 2), and data sharing (Goal 3).

By 2030, the GCRMN should be established as the core framework for aggregating and reporting on open access data on coral reef health and status, responding to national, regional and international priorities. GCRMN's outputs should provide the measure of, and motivate successful global action for, the long-term sustainability of coral reefs worldwide.

7. Appendices

7.1. Annex I. Acronyms

BioEco Panel	Biology and Ecosystems Panel (GOOS)
BIOPAMA	Biodiversity and Protected Areas Management Programme
BIP	Biodiversity Indicators Partnership
CBD	Convention on Biological Diversity's
COTs	Crown of Thorns seastars
DSA	Data Sharing Agreements
EBV	Essential Biodiversity Variable
eDNA	environmental Deoxyribonucleic acid
EOV	Essential Ocean Variable
EV	Essential Variable
FOO	Framework for Ocean Observation
GBIF	Global Biodiversity Information Facility
GCRMN	Global Coral Reef Monitoring Network
GEOBON	Group on Earth Observation's Biodiversity Observation Network
GM	General Meetings
GOA-ON	Global Ocean Acidification Observing Network
GOOS	Global Ocean Observing System
ICRI	International Coral Reef Initiative
IGP	Implementation and Governance Plan
IODE	International Ocean Data and Information Exchange
IPBES	Intergovernmental Science-Policy Platform on Biodiversity and Ecosystem Services
IPCC	Intergovernmental Panel on Climate Change
ISRS	International Society for Reef Studies
IUCN	International Union for the Conservation of Nature
LDC	Least Developed Countries
MBON	Marine Biodiversity Observing System
OBIS	Ocean Biogeographic Information System
OTGA	Ocean Teacher Global Academy
ROPME	Regional Organisation for Protection of the Marine Environment
SDG	Sustainable Development Goal
SIDS	Small Island Developing States
SPA-W-RAC	Specially Protected Areas and Wildlife - Regional Activity Centre (Caribbean)
UNE	United Nations Environment
UNEA	United Nations Environment Assembly
UNEP-WCMC	United Nations Environment Programme - World Conservation Monitoring Centre
UNESCO-IOC	United Nations Education, Scientific and Cultural Organization - Intergovernmental Oceanographic Commission
UNFCCC	UN Framework Convention on Climate Change
WIO	Western Indian Ocean
WOA	World Ocean Assessment
WoRMS	World Register of Marine Species

7.2. Annex II. GCRMN publications

GCRMN and ICRI working group documents laying the foundation for this IGP.

GCRMN documents are publicly available at <https://www.icriforum.org/GCRMN> and ICRI General Meeting decisions and additional background documents at <https://www.icriforum.org/icri-documents/>

1. Value Proposition and Description of the Global Coral Reef Monitoring Network (GCRMN), 21 August 2017]
2. Developing a Roadmap for Strengthening GCRMN: Summary of Consultation Meeting, Townsville, Australia, 23 May 2017
3. GCRMN Working Group, ICRI General Meeting 30, Pattaya, Thailand, 2 December 2015
4. GCRMN Working Group, ICRI General Meeting 29, Okinawa, Japan, 19-20 October 2014
5. Resolution on the Global Coral Reef Monitoring Network (GCRMN). November 4th, 2016, at the 31st ICRI General Meeting (Paris, France)

7.3. Annex III - References cited

- Bax N et al. (2018) Linking capacity development to monitoring networks to achieve sustained ocean observation. In prep.
- Bellwood, D.R. 1996 Production and reworking of sediment by parrotfishes (family Scaridae) on the Great Barrier Reef, Australia. *Marine Biology* 125:795-800.
- Bellwood, D.R., Wainright, P.C., 2002. The history and biogeography of fishes on coral reefs. In: Sale, P.F. (Ed.), *Coral Reef Fishes: Dynamics and Diversity in a Complex Ecosystem*. Academic Press, San Diego, California, USA, pp. 5–32
- Bruno JF, Selig ER (2007) Regional Decline of Coral Cover in the Indo-Pacific: Timing, Extent, and Subregional Comparisons. *PLOS ONE* 2(8): e711. <https://doi.org/10.1371/journal.pone.0000711>
- Bunce, L. and Pomeroy R., (2003). *Socioeconomic Monitoring Guidelines for Coastal Managers in the Caribbean*. World Commission of Protected Areas & Australian Institute of Marine Science.
- Bunce, L., Townsely, P., Pomeroy, R. and Pollnac, R. (2000). *Socioeconomic Manual for Coral Reef Management*. Australian Institute of Marine Science and IUCN, Townsville, Australia
- Choat JH, Bellwood DR (1991) Reef Fishes: Their History and Evolution. In: *The Ecology of Fishes on Coral Reefs*. Ed: Sale P. Pages 39-66
- Conand, C, P Chabanet, J-P Quod and L Bigot (2000). *Manuel Methodologique Pour Le Suivi De L'etat De Sante Des Recifs Coralliens Du Sud-Ouest De L'océan Indien*. Commission Ocean Indien, Mauritius: pp. 27.
- Díaz-Pérez L., Rodríguez-Zaragoza F.A., Ortiz M., Cupul-Magaña A.L., Carriquiry J.D., Ríos-Jara E., Rodríguez-Troncoso A.P., & García-Rivas M.D.C. (2016) Coral Reef Health Indices versus the Biological, Ecological and Functional Diversity of Fish and Coral Assemblages in the Caribbean Sea. *PLoS ONE*, 11, e0161812.
- Donovan MK, Friedlander AM, Lecky J, Jouffray JB, Williams GJ, Wedding LM, Crowder LB, Erickson A, Graham NAJ, Gove JM, Kappel CV, Karr K, Kittinger JN, Norström AV, Nyström M, Oleson KL, Stamoulis KA, White C, Williams ID, Selkoe KA. Integrating fish and benthic communities for a new understanding
- English, S., Wilkinson, C., and Baker, V. (1997). *Survey Manual for Tropical Marine Resources*. Townsville, Australia. Australian Institute of Marine Science.
- Florida Reef Resilience Program (2004) *Florida Reef Tract: Coral Bleaching Response Plan NOAA/TNC*. pp32.
- GEOBON (undated) National, regional and thematic Biodiversity Observation Networks (BONs): Background and criteria for endorsement
- IPCC (2018) Global warming of 1.5 °C. An IPCC special report on the impacts of global warming of 1.5 °C above pre-industrial levels and related global greenhouse gas emission pathways, in the context of strengthening the global response to the threat of climate change, sustainable development, and efforts to eradicate poverty. Summary for Policymakers. 6 October 2018.
- Jackson, JBC, Donovan M, Cramer K, Lam V. (2014) Status and Trends of Caribbean Coral Reefs: 1970-2012. *GCRMN/ICRI/UNEP/IUCN*. Pp. 245.
- Kelble C.R., Loomis D.K., Lovelace S., Nuttle W.K., Ortner P.B., Fletcher P., Cook G.S., Lorenz J.J., Boyer J.N. (2013) The EBM-DPSER Conceptual Model: Integrating Ecosystem Services into the DPSIR Framework. *PLOS ONE*. <https://doi.org/10.1371/journal.pone.0070766>
- Kittinger, J.N., Finkbeiner, E.M., Glazier, E.W., and Crowder, L.B. (2012). Human Dimensions of Coral Reef Social-Ecological Systems. *Ecology and Society* 17(4): 17. <http://dx.doi.org/10.5751/ES-05115-170417>.
- Marshall P. and Schuttenberg H (2006) – *A Reef Manager's Guide to Coral Bleaching*. NOAA/GBRMPA/IUCN. ISBN 1 876945 40 0. 178 pp.
- Marshall, P. (2003). *Great Barrier Reef Coral Bleaching Response Program*. Great Barrier Reef Marine Park Authority, Australia
- Miloslavich P, & 41 others (2016) Extent of Assessment of Marine Biological Diversity. In: *The First Global Integrated Marine Assessment - World Ocean Assessment I*. Chapter 35. (Coordinators) Lorna Inniss and Alan Simcock The Group of Experts of the Regular Process. C. United Nations. http://www.un.org/Depts/los/global_reporting/WOA_RegProcess.htm
- Miloslavich P, Bax NJ, Simmons SE, et al. (2018) Essential ocean variables for global sustained observations of biodiversity and ecosystem changes. *Glob Change Biol*. 2018;00:1–18. <https://doi.org/10.1111/gcb.14108>
- Moritz C, Vii J, Lee Long W, Tamelander J, Thomassin A, Planes S (editors). (2018) Status and Trends of Coral Reefs of the Pacific. *Global Coral Reef Monitoring Network*.
- Muller-Karger FE, et al. (2018) Advancing Marine Biological Observations linking the Essential Ocean Variables (EOVs) and Essential Biodiversity Variables (EBVs) Frameworks. *Front. Mar. Sci*.
- Navarro L.M., et al. (2018) ScienceDirectMonitoring biodiversity change through effective global coordination. *Current Opinion in Environmental Sustainability*, 29, 158–169.
- Newton J.A., Feely R. A., Jewett E. B., Williamson P. & Mathis J., 2015. *Global Ocean Acidification Observing Network: Requirements and Governance Plan*. Second Edition, GOA-ON, http://www.goa-on.org/docs/GOA-ON_plan_print.pdf.
- Obura DO (2014) Coral reef monitoring in the Western Indian Ocean islands. A manual. Developed for the SW Indian Ocean islands GCRMN node through the ISLANDS project Coral Reef Facility. Indian Ocean Commission. 68 pp.
- Obura DO, Gudka M, Abdou Rabi F, Bacha Gian S, Bigot L, Bijoux J, Freed S, Maharavo J, Munbodhe V, Mwaura J, Porter S, Sola E, Wickel J, Yahya S and Ahamada S (2017) Coral reef status report for the Western Indian Ocean. *Global Coral Reef Monitoring Network (GCRMN)/International Coral Reef Initiative (ICRI)*. pp 144.

- Obura DO et al. (2019) Coral Reef Monitoring, Reef Assessment Technologies, and Ecosystem-based Management. *Frontiers in Marine Science* (Special issue on Community White Papers of OceanObs'19). <https://www.frontiersin.org/research-topics/8224/oceanobs19-an-ocean-of-opportunity>
- Oliver, J, P. Marshall, N. Setiasih and L. Hansen (2004). A global protocol for assessment and monitoring of coral bleaching. WorldFish Center, Penang, Malaysia and WWF Indonesia, Jakarta. 35 p.
- Patrício J., Elliott M., Mazik K., Papadopoulou K.-N., & Smith C.J. (2016) DPSIR—Two Decades of Trying to Develop a Unifying Framework for Marine Environmental Management? *Frontiers in Marine Science*, 3, 225.
- Pereira H.M., et al. (2013) Essential Biodiversity Variables. *Science* (339), 277-278. [DOI:10.1126/science.1229931]
- Samoilys MA & Randriamanantsoa B (2011) Reef fishes of northeast Madagascar. In: Obura D., Di Carlo, G., Rabearisoa, A. and Oliver, T. (editors). 2011. A Rapid Marine Biodiversity Assessment of the coral reefs of northeast Madagascar. RAP Bulletin of Biological Assessment 61. Conservation International. Arlington, VA. pp 29-39.
- Smith, Jennifer E., et al. "Re-evaluating the health of coral reef communities: baselines and evidence for human impacts across the central Pacific." *Proc. R. Soc. B* 283.1822 (2016): 20151985.
- Tittensor D.P., et al. (2014) A mid-term analysis of progress toward international biodiversity targets. *Science*, 346, 241–244
- UNEP (2016) GCRMN-Caribbean Guidelines for Coral Reef Biophysical Monitoring. UNEP(DEPI)/CAR WG.38/INF.17 12 October 2016
- UNESCO (2012) A Framework for Ocean Observing. By the Task Team for an Integrated Framework for Sustained Ocean Observing, UNESCO 2012, IOC/INF-1284, doi: 10.5270/OceanObs09-FOO
- van Hoodonk R., Maynard J., Tamelander J., Gove J., Ahmadi G., Raymundo L., Williams G., Heron S.F., & Planes S. (2016) Local-scale projections of coral reef futures and implications of the Paris Agreement. *Scientific Reports*, 1–8.
- Wilkinson C, Souter D, Goldberg J (2005) Status of coral reefs in tsunami affected countries: 2005. GCRMN, Australian Institute of Marine Science. 160 pp.
- Wongbusarakum, S., Madeira, E.M., and Hartanto, H. (2014). *Strengthening the Social Impacts of Sustainable Landscapes Programs: A practitioner's guidebook to strengthen and monitor human well-being outcomes*. Arlington, VA: The Nature Conservancy.
- UNEP/SPAW (2017) GCRMN-Caribbean Guidelines For Integrated Coral Reef Monitoring. Protocol Concerning Specially Protected Areas and Wildlife (SPAW) in the Wider Caribbean Region. 13 March 2017. United Nations Environment Programme.